

# JESSE RAST ENTERPRISES

If you need your equipment **FAST** stick with the **RAST!**

## Independent Distributor **CATALOGUE**



**BEFCO**

JesseRastEnterprises.com 803-420-4102

# About Us

Rast Family Farms have been in operation since 1889, harvesting generations of appreciation for hard work, honesty, and dependability. Southern living at it's finest, and hardest of times. Through it all – we pull together, for the love of God, Family, Land, and Selflessness.

Jesse Rast Enterprises has taken the family values from decades of farming, planting the seed for a better way to procure farm and agricultural equipment by eliminating “the man”, speeding up delivery, and doing what’s right. Family is special and we choose to specialize in farm and agricultural equipment.

Unlike traditional distribution, Jesse Rast Enterprises runs the equipment that is available in our portfolio.

Farm life is not transactional, and you will feel the difference in honest guidance and feedback by becoming a part of the Jesse Rast Enterprises family.



**BEFCO**®

**JESSE RAST ENTERPRISES**



# CYCLONE C30-CE5



## Three spindle engine driven grooming mower

- Ideal for lawn tractors, ATVs & UTVs.
- Rear discharge.
- 4 solid rubber tires to guarantee a perfectly level cut.
- Stamped steel reinforced wheel arm attached by 5 bolts for maintaining a consistent cutting height.
- Spindle shafts greased from the top for easy service.
- Hitch: Cat. 1 ball for rear mounting and 2" receiver hitch for front mounting.
- 10 gauge reinforced mower deck.
- Cutting heights: from 1" to 4".
- Heavy duty reinforced belts (BX).
- Powerful 11.5 HP Briggs & Stratton (OHV) engine with centrifugal clutch.
- 3 quart fuel tank.
- Safety kill switch.
- Heavy duty, one piece, balanced steel pulleys.
- Stamped steel wheel yokes.



## STANDARD

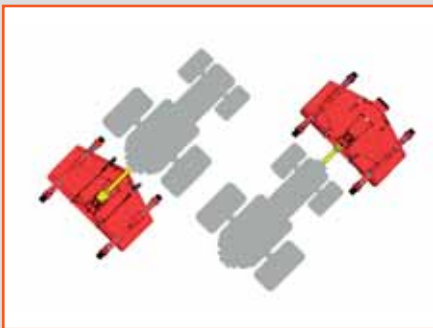

Reversible hitch for front or rear mounting



Capable of being center mounted or offset left or right



Up to 75" offset

## C30-CE5H



in

in

in

lbs

lbs

rpm

fpm

N°

in

N°

N°-in

60"

62"

0-75"

460

600

2,673

14,173

3

1"-4"

2 BX

4-8.4"x3.2"

Briggs  
& Stratton  
11.5 HP



Front mount application with 2" receiver hitch



Height adjustment bar

**JESSE RAST ENTERPRISES (803) 420-4102**



# CYCLONE C30

16-30 HP (12-22 KW)  
540 rpm - cat. 1



## Rear discharge three spindle grooming mower

- Highly engineered & rugged gearbox.
- Front & rear tractor mounting.
- 4 rubber swivel tires to guarantee a perfectly level cut.

- Floating 3 point linkage, cat. 1.
- 10 gauge reinforced mower deck.
- Stamped steel reinforced wheel arm attached by 5 bolts for maintaining a consistent cutting height.
- Stamped steel wheel yokes.
- Cutting heights: from 1" to 4".
- Spindle shafts greased from the top for easy service.
- Heavy duty reinforced belt (BX).
- Heavy duty, one piece, balanced steel pulleys.
- Heavy duty shielded PTO shaft ( $1\frac{3}{8}$ " ASAE cat. 2).



Heavy duty reinforced belt (BX) with automatic belt tensioner



Axial grease fittings for easy and accurate lubrication

## STANDARD



Reversible three point hitch for front or rear tractor mounting



Gearboxes manufactured by Befco















Stamped steel wheel arms attached by five bolts



Choice of hard or air tires



**JESSE RAST ENTERPRISES (803) 420-4102**

MODEL	C30-RD4H	C30-RD5H	C30-RD6H	C30-RD4A	C30-RD5A	C30-RD6A	
	HARD TIRES			AIR TIRES			
	HP	16-30	20-30	25-30	16-30	20-30	25-30
	in	48"	60"	72"	48"	60"	72"
	in	51"	62"	74"	51"	62"	74"
	lbs	340	375	440	329	364	429
	lbs	440	490	570	429	479	559
	rpm	3,037	2,803	2,278	3,037	2,803	2,278
	fpm	13,188	14,763	14,566	13,188	14,763	14,566
	N°	3	3	3	3	3	3
	in	1"-4"	1"-4"	1"-4"	1"-4"	1"-4"	1"-4"
	N°	1 BX	1 BX	1 BX	1 BX	1 BX	1 BX
	N°-in	4-8.4"x3.2"	4-8.4"x3.2"	4-8.4"x3.2"	4-9"x3.5"	4-9"x3.5"	4-9"x3.5"
	1 3/8"	ASAE cat. 2	ASAE cat. 2	ASAE cat. 2	ASAE cat. 2	ASAE cat. 2	ASAE cat. 2



**JESSE RAST ENTERPRISES (803) 420-4102**



# CYCLONE C50

20-50 HP (15-37 KW)  
540 rpm - cat. 1



## Rear discharge three spindle grooming mower

- Highly engineered & rugged gearbox with cooling fins.
- Spiral gears guarantee strength and quietness.
- Cutting heights: from 1" to 5".
- Front & rear tractor mounting.
- 4 rubber swivel tires with bearings to guarantee a perfectly level cut.
- Stamped steel reinforced wheel arm attached by 8 bolts for maintaining a consistent cutting height.
- Floating 3 point linkage, cat. 1.
- 8 gauge reinforced mower deck.
- Spindle shafts greased from the top for easy service.
- Safety chain shield standard.
- Two heavy duty reinforced belts (SPBX).
- Heavy duty, one piece, balanced steel pulleys.
- Heavy duty shielded PTO shaft (1.375" ASAE cat. 3).
- Stamped steel wheel yokes.

## STANDARD



Reversible three point hitch for front & rear tractor mounting



Gearboxes, manufactured by Befco, equipped with spiral gears ensure better power transmission, increase longevity and reduce noise



Choice of standard blades, high lift blades, mulching blades and flat blades















Choice of hard or air tires with ball bearings



**JESSE RAST ENTERPRISES (803) 420-4102**



MODEL	C50-RD5H	C50-RD6H	C50-RD7H	C50-RD5A	C50-RD6A	C50-RD7A	
	HARD TIRES			AIR TIRES			
	HP	20-50	25-50	30-50	20-50	25-50	30-50
	in	60"	72"	84"	60"	72"	84"
	in	62"	74"	86"	62"	74"	86"
	lbs	550	600	690	534	584	674
	lbs	665	730	835	649	714	819
	rpm	3,210	2,605	2,195	3,210	2,605	2,195
	fpm	16,929	16,732	16,338	16,929	16,732	16,338
	N°	3	3	3	3	3	3
	in	1"-5"	1"-5"	1"-5"	1"-5"	1"-5"	1"-5"
	N°	2 SPBX	2 SPBX	2 SPBX	2 SPBX	2 SPBX	2 SPBX
	N°-in	4-10"x3.2"	4-10"x3.2"	4-10"x3.2"	4-11"x4"	4-11"x4"	4-11"x4"
	1 3/8"	ASAE cat. 3	ASAE cat. 3	ASAE cat. 3	ASAE cat. 3	ASAE cat. 3	ASAE cat. 3



Axial grease fittings for easy and accurate spindle lubrication



Two heavy duty reinforced belts (SPBX) with manual tensioner provide over 180° coverage of all pulleys and reduce belt maintenance

**JESSE RAST ENTERPRISES (803) 420-4102**



## CYCLONE C70

30-70 HP (22-52 KW)  
540 rpm - cat. 1



### Heavy duty rear discharge three spindle grooming mower













- Highly engineered & rugged gearbox with cooling fins.
- Cutting heights: from 1.3" to 5.3".
- Front & rear tractor mounting.
- 4 rubber swivel tires with bearings to guarantee a perfectly level cut.
- Stamped steel reinforced wheel arm attached by 8 bolts for maintaining a consistent cutting height.

- Floating 3 point linkage, cat. 1.
- Front antiscalping roller standard.
- 8 gauge reinforced mower deck.
- Three spindle rotors with free swinging blades per rotor.
- Spindle shafts greased from the top for easy service.
- Two heavy duty reinforced belts (CX).
- Heavy duty, one piece, balanced steel pulleys.
- Heavy duty shielded PTO shaft (1.375" ASAE cat. 4).
- Safety chain shield standard.
- Stamped steel wheel yokes.



**JESSE RAST ENTERPRISES (803) 420-4102**



MODEL	C70-090H	C70-110H	C70-090A	C70-110A	
	HARD TIRES		AIR TIRES		
	HP	30-70	40-70	30-70	40-70
	in	90"	110"	90"	110"
	in	92"	112"	92"	112"
	lbs	1,237	1,390	1,137	1,290
	lbs	1,267	1,420	1,167	1,320
	rpm	1,750	1,562	1,750	1,562
	fpm	14,106	14,998	14,106	14,998
	Nº	6	6	6	6
	in	1.3"-5.3"	1.3"-5.3"	1.3"-5.3"	1.3"-5.3"
	Nº	2 CX	2 CX	2 CX	2 CX
	Nº-in	4-12"x4"	4-12"x4"	4-13"x6.5"	4-13"x6.5"
	1 3/8"	ASAE cat. 4	ASAE cat. 4	ASAE cat. 4	ASAE cat. 4



Standard front antisclap roller



Rotor with free swinging blades

## STANDARD

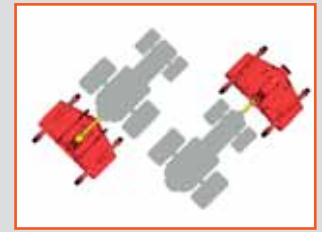

Reversible three point hitch for front or rear tractor mounting



Gearboxes manufactured by Befco



Stamped steel wheel arms attached by eight bolts



Choice of hard or air tires



Axial grease fittings for easy and accurate spindle lubrication



Chains provide safety from thrown objects

# CYCLONE FLEX

25-80 HP (19-60 KW)  
540 rpm



## Pull type gang grooming mowers

- Heavy duty transport frame.
- Cutting heights: from 1" to 5".
- Pull type mower with high flotation transport tires (20.5"x8"x10").
- Single action hydraulic folding wing system for easy transport & storage.
- Transport width 8'4" max.
- Telescoping wings that allow for adjustable cutting width to increase or decrease mower overlap.
- Constant velocity driveline with slip clutch (•• $\frac{3}{4}$ " ASAE cat. 6).
- Stamped steel reinforced wheel arm attached by 8 bolts for maintaining a consistent cutting height.
- 3 front antiscalping rollers standard.
- Safety chain shield standard.
- 8 gauge reinforced mower decks.
- Remote safety locks for local transport & deck kick out attachments.
- Completely independent free floating mowing decks for a perfect cut on uneven terrain.
- Unique double pivot floating linkage.
- 12 rubber tires with bearings (4 per deck) to guarantee a perfectly level cut.
- Heavy duty, one piece, balanced steel pulleys.
- Two heavy duty reinforced belts per deck (SPBX).
- Single unit gearboxes with cooling fins.
- Spiral gears guarantee strength and quietness.
- Stamped steel wheel yokes.
- Single unit driveline with shear pin safety.











### STANDARD



Gearboxes, manufactured by Befco, equipped with spiral gears ensure better power transmission, increase longevity and reduce noise

**JESSE RAST ENTERPRISES (803) 420-4102**



MODEL	312-FLXH	315-FLXH	317-FLXH	312-FLXA	315-FLXA	317-FLXA	
	HARD TIRES			AIR TIRES			
	HP	25-80	30-80	35-80	25-80	30-80	35-80
	ft	12'	15'	17'	12'	15'	17'
	in	91"	97"	100"	91"	97"	100"
	in	74"	92"	103"	74"	92"	103"
	lbs	2,742	2,874	2,995	2,694	2,826	2,947
	Nº	9	9	9	9	9	9
	in	1"-5"	1"-5"	1"-5"	1"-5"	1"-5"	1"-5"
	Nº	6 SPBX	6 SPBX	6 SPBX	6 SPBX	6 SPBX	6 SPBX
	Nº-in	12-10"x3.2"	12-10"x3.2"	12-10"x3.2"	12-11"x4"	12-11"x4"	12-11"x4"
	Nº/ft	2-4' mowers & 1-5' mower	2-5' mowers & 1-6' mower	3-6' mowers	2-4' mowers & 1-5' mower	2-5' mowers & 1-6' mower	3-6' mowers
	1 3/8"	ASAE cat. 6 cv, slip clutch	ASAE cat. 6 cv, slip clutch	ASAE cat. 6 cv, slip clutch	ASAE cat. 6 cv, slip clutch	ASAE cat. 6 cv, slip clutch	ASAE cat. 6 cv, slip clutch



The frame design along with our CV driveline allows Flex mowers to circle trees and obstacles in one pass where competitors require multiple passes.



Hexagonal yokes on front tires of rear mower deck to prevent slippage on slopes



Standard front antiscalping roller

**JESSE RAST ENTERPRISES (803) 420-4102**



## CYCLONE SUPER-FLEX

35-80 HP (26-60 KW)  
540 rpm

### Pull type gang grooming mowers

- Extra heavy duty transport frame.
- Cutting heights: from 1" to 5".
- Pull type mower with high flotation transport tires (23"x10.5"x12").
- Single action hydraulic folding wing system for easy transport & storage.
- 3 front antiscalping rollers standard.
- Telescoping wings that allow for adjustable cutting width to increase or decrease mower overlap.
- Constant velocity driveline with slip clutch (3/4" ASAE cat. 6).
- Stamped steel reinforced wheel arm attached by 8 bolts for maintaining a consistent cutting height.
- Stamped steel wheel yokes.
- 8 gauge reinforced mower deck.













- Safety chain shield standard.
- Single unit driveline with shear pin safety.
- Remote safety locks for local transport & deck kick out attachments.
- Completely independent free floating mowing decks for a perfect cut on uneven terrain.
- Unique double pivot floating linkage.
- 12 rubber tires with bearings (4 per deck) to guarantee a perfectly level cut.
- Wide high flotation air tires 13"x6.5".
- Heavy duty, one piece, balanced steel pulleys.
- Two heavy duty reinforced belts per deck (SPBX).
- Single unit gearboxes with cooling fins.
- Spiral gears guarantee strength and quietness.



**JESSE RAST ENTERPRISES (803) 420-4102**



MODEL		412-SFL	415-SFL	417-SFL	420-SFL
	HP	35-80	40-80	45-80	50-80
	ft	12'	15'	17'	20'
	in	91"	97"	100"	114"
	in	74"	92"	103"	116"
	lbs	3,090	3,267	3,438	3,747
	N°	9	9	9	9
	in	1"-5"	1"-5"	1"-5"	1"-5"
	N°	6 SPBX	6 SPBX	6 SPBX	6 SPBX
	N°-in	12-13"x6.5"	12-13"x6.5"	12-13"x6.5"	12-13"x6.5"
	N°-ft	2-4' mowers & 1-5' mower	2-5' mowers & 1-6' mower	3-6' mowers	3-7' mowers
	1 3/8"	ASAE cat. 6 cv, slip clutch	ASAE cat. 6 cv, slip clutch	ASAE cat. 6 cv, slip clutch	ASAE cat. 6 cv, slip clutch



## STANDARD



Double pivot floating linkage for a perfect cut on uneven terrain



Telescopic wings that allow for adjustable cutting width to increase or decrease mower overlap



Gearboxes, manufactured by Befco, equipped with spiral gears to increase strength and quietness



Air tires 13"x6.5"



Heavy duty center-splitter gearbox



Hexagonal yokes on front tires of rear mower deck prevent slippage on slopes

# HURRICANE H40-S

16-40 HP (12-30 KW)  
540 rpm - cat. 1















## Side-shift flail mower

- Cutting heights: from  $\frac{3}{4}$ " to 2  $\frac{3}{8}$ ".
- Manual or optional hydraulic side-shift up to 16".
- Dual rear roller mounting position, inside or outside the cutting chamber.
- Manual belt tensioner without spring loaded idlers.
- Choice of fine cut blades at 90° angles, reverse "Y" blades, paddle blades or hammer type blades.
- Dethatching blades available.
- Adjustable cutting height roller with scraper or self cleaning roller when mounted inside the cutting chamber.
- Heavy duty shielded PTO shaft (1  $\frac{3}{8}$ " ASAE cat. 3).
- Sealed rotor bearings.
- Front & rear tractor mounting.
- Heavy duty, one piece, balanced steel pulleys.
- 2 Heavy duty reinforced notched belts (SPBX).
- 3 point linkage, cat. 1.
- Standard front rubber safety shielding or optional front steel deflectors.



**JESSE RAST ENTERPRISES (803) 420-4102**



MODEL		H40-S48	H40-S60	H40-S72
	HP	16-40	20-40	25-40
	in	48"	60"	72"
	in	54"	64"	76"
	in	35"	46"	58"
	lbs	552	624	697
	lbs	690	762	835
	rpm	2,278	2,278	2,278
	fpm	8,858	8,858	8,858
	N°	48	64	76
	in	¾"-2 ¾"	¾"-2 ¾"	¾"-2 ¾"
	N°	2 SPBX	2 SPBX	2 SPBX
	1 ¾"	ASAE cat. 3	ASAE cat. 3	ASAE cat. 3



## STANDARD

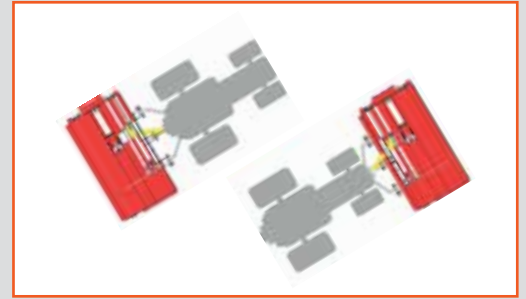

Reversible three point hitch for front or rear tractor mounting

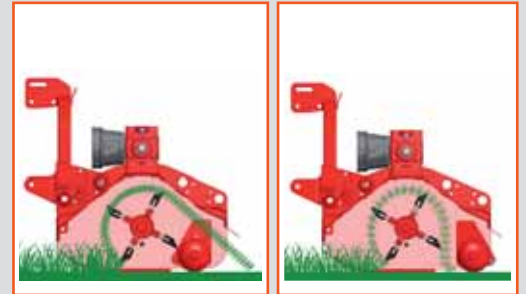

Dual rear roller mounting position, inside or outside the cutting chamber

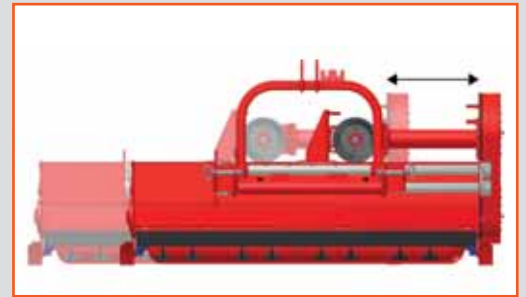

Manual or hydraulic side-shift up to 16"



Manual belt tensioning

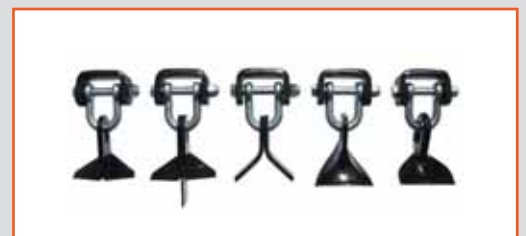

Choice of fine cut blades, dethatching blades, reverse 'Y' blades, paddle blades or hammer type blades

# HURRICANE H70

30-70 HP (22-52 KW)  
540 rpm - cat. 1 & 2













## Flail mower

- Cutting heights: from  $\frac{3}{4}$ " to 6".
- Choice of fine cut blades at 90° angles, reverse "Y" blades, paddle blades or hammer type blades.
- Dethatching blades available.
- Adjustable cutting height roller with scraper.
- Driveline with overrunning clutch (1  $\frac{3}{8}$ " ASAE cat. 4).
- Highly engineered & rugged gearbox.
- Belt shield fender.
- Front & rear tractor mounting.
- Electronically balanced rotor.
- Heavy duty, one piece, balanced steel pulleys.
- 2 heavy duty reinforced notched belts (CX).
- Manual belt tensioner.
- 3 point linkage, cat. 1 & 2.
- Floating top link.
- Forward & reverse rotor rotation; clockwise is standard.
- Cast iron rotor supports with spherical roller bearings.
- Rubber safety shielding.
- Replaceable skids.





MODEL		H70-060	H70-072	H70-088
	HP	30-70	35-70	40-70
	in	60"	72"	88"
	in	71"	85"	99"
	lbs	869	955	1,078
	lbs	1,045	1,145	1,298
	rpm	2,080	2,080	2,080
	fpm	8,464	8,464	8,464
	N°	64	80	96
	in	3/4"-6"	3/4"-6"	3/4"-6"
	N°	2 CX	2 CX	2 CX
	1 3/8"	ASAE cat. 4 overrunning clutch	ASAE cat. 4 overrunning clutch	ASAE cat. 4 overrunning clutch



## STANDARD

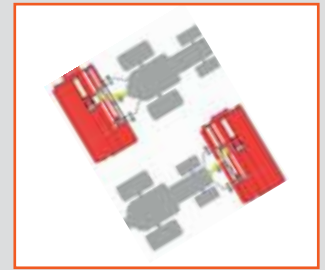

Reversible three point hitch for front or rear tractor mounting



Gearboxes manufactured by Befco



Belt shield fender



Cast iron rotor support with spherical roller bearings



Replaceable side skids



Adjustable cutting height roller with scraper

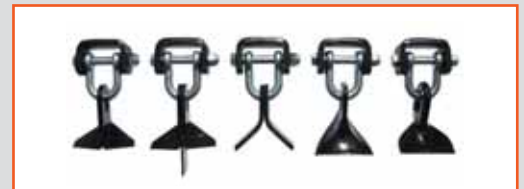

Choice of fine cut blades, dethatching blades, reverse 'Y' blades, paddle blades or hammer type blades

# DESTROYER D90









40-90 HP (30-67 KW)  
540 rpm - cat. 1 & 2

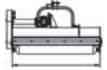
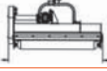

## Commercial flail shredder with hydraulic side-shift

- Cutting heights: from 3/4" to 5".
- 3 point linkage, cat. 1 & 2.
- Front & rear tractor mounting.
- Driveline with overrunning clutch (1 3/8" ASAE cat. 6).
- Belt driven transmission with four heavy duty XPBX type belts and manual belt tensioner.
- Hydraulic side-shift with dual remotes.
- 12" side-shift on 60" model 16" on 72" & 88" models.
- Heavy duty hammer type blades.
- 2" cutting capacity.
- Rotor diameter 5 1/4", 5/16" thick rotor tube.
- Height adjustment rear roller with scraper standard.
- Rear roller diameter 6 5/8", 3/16" thick rotor tube.



MODEL		D90-060	D90-072	D90-088
	HP	40-90	50-90	60-90
	in	60"	72"	88"
	in	69"	81"	96"
	in	43"	54"	61"
	lbs	1,257	1,345	1,491
	lbs	1,360	1,450	1,600
	rpm	1,961	1,961	1,961
	fpm	8,268	8,268	8,268
	N°	16	20	24
	in	¾"-5"	¾"-5"	¾"-5"
	N°	4 XPBX	4 XPBX	4 XPBX
	1 ⅜"	ASAE cat. 6 overrunning clutch	ASAE cat. 6 overrunning clutch	ASAE cat. 6 overrunning clutch



## STANDARD

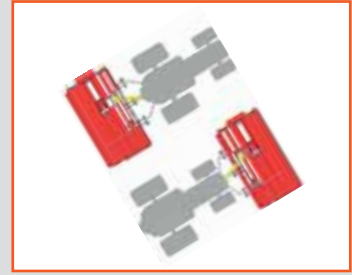

Reversible three point hitch for front or rear tractor mounting



Hammer type blades ideal for stalks up to 2" in diameter



Hydraulic cylinder for side shift



Rear roller for cutting height adjustment equipped with roller scraper







Four belts transmission

# QUICK HITCH



- ASABE cat. 1 Quick Hitch.
- Works with all BEFCO cat. 1 Quick Hitch compatible implements.
- Look for the  symbol throughout the catalog for compatible implements.
- Optional floating Quick Hitch Adapter for C30, C50 & C70 grooming mowers. Adapter allows mowers to maintain its full float capability while using Quick Hitch.
- Optional Quick Hitch adapter available for Hop 203 fertilizer spreader.

MODEL	QH1-100	
		Cat. 1
	in	30 1/2"
	in	22"
	in	8"
	lbs	57





# TORNADO BRC

• 20-60 HP (15-45 KW)  
• 540 rpm - cat. 1



## Standard duty rotary cutters

- Cutting heights: from 1" to 9 1/4".
- 10 gauge reinforced deck.
- Heavy duty shielded PTO shaft with shear bolt or slip clutch safety (1 3/8" ASAE cat. 4).
- Oval stump jumper standard on 48", 60" & 72" sizes.
- Spring steel blades.
- 1" cutting capacity.
- Front & rear safety shields standard.
- Laminated tail wheel (4"x8"x15").
- 3 point linkage, cat. 1.
- Floating top link.
- Round back frame.

MODEL	BRC-142	BRC-148	BRC-160	BRC-172	BRC-242	BRC-248	BRC-260	BRC-272
	SHEAR BOLT				SLIP CLUTCH			
HP	20-60	25-60	30-60	35-60	20-60	25-60	30-60	35-60
in	42"	48"	60"	72"	42"	48"	60"	72"
in	47"	56"	68"	79"	47"	56"	68"	79"
lbs	383	443	528	601	401	461	539	612
lbs	397	457	591	675	415	475	613	686
rpm	1,042	1,042	794	794	1,042	1,042	794	794
fpm	11,437	12,560	11,948	14,232	11,437	12,560	11,948	14,232
N°-in	2-3/8" x 2 3/4"	2-3/8" x 2 3/4"	2-1/2" x 3"	2-1/2" x 3"	2-3/8" x 2 3/4"	2-3/8" x 2 3/4"	2-1/2" x 3"	2-1/2" x 3"
in	1"-9 1/4"	1"-9 1/4"	1"-9 1/4"	1"-9 1/4"	1"-9 1/4"	1"-9 1/4"	1"-9 1/4"	1"-9 1/4"
N°-in	1-4"x8"x15"	1-4"x8"x15"	1-4"x8"x15"	1-4"x8"x15"	1-4"x8"x15"	1-4"x8"x15"	1-4"x8"x15"	1-4"x8"x15"
1 3/8"	ASAE cat. 4 shear bolt	ASAE cat. 4 shear bolt	ASAE cat. 4 shear bolt	ASAE cat. 4 shear bolt	ASAE cat. 4 slip clutch	ASAE cat. 4 slip clutch	ASAE cat. 4 slip clutch	ASAE cat. 4 slip clutch

**WARNING:** Because of possible injury from thrown objects, all rotary cutters are potentially dangerous. Any rotary cutter intended for use along roadways or other locations where people may be present must be used with safety shielding in place.

# TORNADO RMD

35-80 HP (26-60 KW)  
540 rpm - cat. 1

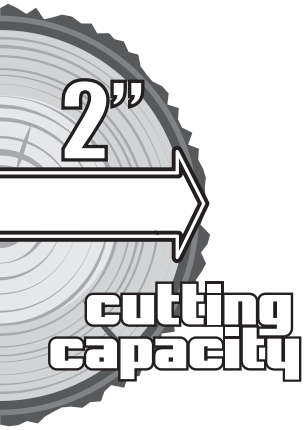

## Medium duty rotary cutters

- Cutting heights: from 1" to 9 1/4".
- Replaceable skids.
- Highly engineered & rugged gearbox.
- Heavy duty shielded PTO shaft with slip clutch safety (1 3/8" ASAE cat. 4).
- 3 point linkage, cat. 1.
- Floating top link.
- Exceptionally heavy duty 1/2"x4" spring steel blades.
- 2" cutting capacity.
- Laminated tail wheel with tapered roller bearings (4"x8"x15").
- Oval heavy duty stump jumper standard.
- Heavy duty reinforced 8 gauge deck.
- Front & rear protective chain shields standard.

### WARNING:

Because of possible injury from thrown objects, all rotary cutters are potentially dangerous. Any rotary cutter intended for use along roadways or other locations where people may be present must be used with safety shielding in place.

MODEL		RMD-360	RMD-372
	HP	35-80	40-80
	in	60"	72"
	in	68"	80"
	lbs	695	785
	lbs	695	785
	rpm	855	855
	fpm	13,189	15,748
	N°-in	2-1/2"x4"	2-1/2"x4"
	in	1"-9 1/4"	1"-9 1/4"
	N°-in	1-4"x8"x15"	1-4"x8"x15"
	1 3/8"	ASAE cat. 4 slip clutch	ASAE cat. 4 slip clutch

## STANDARD



Laminated tail wheel



Carbon steel rotor with free swinging blades



Safety chains & shields



Replaceable side skids





# TORNADO RHD

50-100 HP (37-74 KW)  
540 rpm - cat. 1 & 2

3"

cutting capacity

## Heavy duty rotary cutters



- Cutting heights: from 2" to 8".
- Replaceable skids.
- Highly engineered & rugged gearbox.
- Heavy duty shielded PTO shaft with slip clutch safety (1 3/8" ASAE cat. 6).
- 3 point linkage, cat. 1 & 2.
- Floating top link.
- Front & rear protective chain shields standard.
- Exceptionally heavy duty 1/2"x4" spring steel blades.
- 3" cutting capacity.
- Laminated tail wheel with tapered roller bearings (5"x8"x15").
- Oval heavy duty stump jumper standard.
- Heavy duty reinforced deck.

### WARNING:









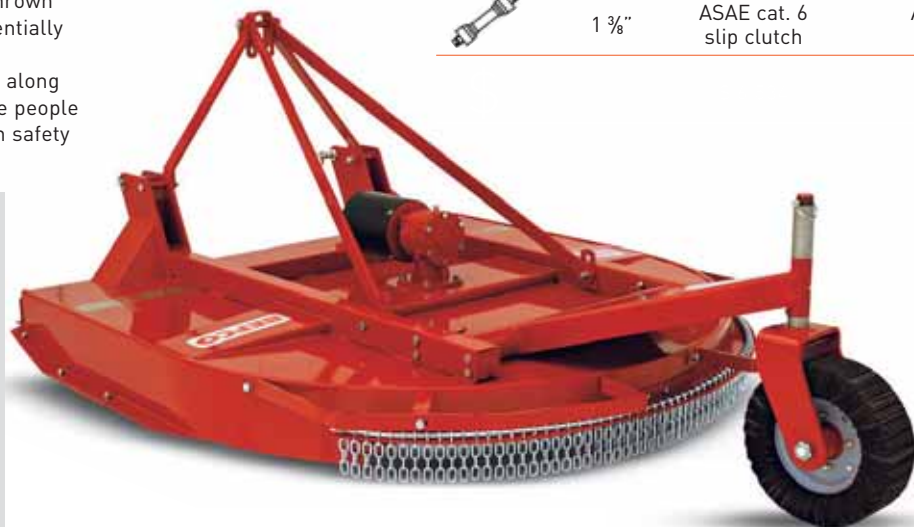

Because of possible injury from thrown objects, all rotary cutters are potentially dangerous.

Any rotary cutter intended for use along roadways or other locations where people may be present must be used with safety shielding in place.



Heavy duty free swinging blades mounted on a high carbon steel rotor protected by an oval stump jumper



MODEL		RHD-472	RHD-484
	HP	50-100	60-100
	in	72"	84"
	in	76"	88"
	lbs	1,025	1,200
	lbs	1,025	1,200
	rpm	748	748
	fpm	13,878	16,191
	N°-in	2-1/2"x4"	2-1/2"x4"
	in	2" - 8"	2" - 8"
	N°-in	1-5"x8"x15"	1-5"x8"x15"
	1 3/8"	ASAE cat. 6 slip clutch	ASAE cat. 6 slip clutch













# TILL-RITE T30

16-30 HP (12-22 KW)  
540 or 2000 rpm - cat. 1



**JESSE RAST ENTERPRISES (803) 420-4102**



MODEL	T30-134	T30-142	T30-150	T30-234	T30-242	T30-250	T30-534	T30-542	T30-550
	SHEAR BOLT 540 rpm			SLIP CLUTCH 540 rpm			SHEAR BOLT 2000 rpm		
 HP	16-30	20-30	25-30	16-30	20-30	25-30	16-30	20-30	25-30
 in	34"	42"	50"	34"	42"	50"	34"	42"	50"
 in	39"	47"	55"	39"	47"	55"	39"	47"	55"
 in	24"	32"	40"	24"	32"	40"	24"	32"	40"
 lbs	297	341	374	308	352	385	297	341	374
 lbs	387	430	463	398	441	474	387	430	463
 N°	4	5	6	4	5	6	4	5	6
 N°	16	20	24	16	20	24	16	20	24
 z	14-16	14-16	14-16	14-16	14-16	14-16	9-22	9-22	9-22
 rpm	205	205	205	205	205	205	237	237	237
 in	7 1/4"	7 1/4"	7 1/4"	7 1/4"	7 1/4"	7 1/4"	7 1/4"	7 1/4"	7 1/4"
 1 3/8"	ASAE cat. 2 shear bolt	ASAE cat. 2 shear bolt	ASAE cat. 2 shear bolt	ASAE cat. 3 slip clutch	ASAE cat. 3 slip clutch	ASAE cat. 3 slip clutch	ASAE cat. 2 shear bolt	ASAE cat. 2 shear bolt	ASAE cat. 2 shear bolt

## Rotary tiller with manual side-shift Forward or reverse tilling rotation

- Highly engineered & rugged gearbox.
- Smooth manual side-shift system.
- Adjustable side skids for working depth control.
- Heavy duty shielded PTO shaft with shear bolt coupling (1 3/8" ASAE cat. 2) or slip clutch safety (1 3/8" ASAE cat. 3).
- Max. working depth 7 1/4".
- Parking stand.
- Reinforced lateral ASA 60 chain drive transmission in oil bath.
- Four blades per flange.
- High carbon solid steel round rotor shaft allows for a deeper working depth.
- Outward turned blades keep the rotor supports clean and maximize working width.
- Heavy duty full size blades.
- 3 point linkage, cat. 1.

### STANDARD



Manual side-shift



Forward or reverse tilling rotation



Gearbox manufactured by Befco



Lateral ASA 60 chain drive transmission in oil bath



Side skids for working depth control



## TILL-RITE T40

20-40 HP (15-30 KW)  
540 rpm - cat. 1

### Rotary tiller with manual side-shift Forward or reverse tilling rotation

- Highly engineered & rugged gearbox.
- Smooth manual side-shift system.
- Adjustable side skids for working depth control.
- Heavy duty shielded PTO shaft with shear bolt coupling or slip clutch safety (1 3/8" ASAE cat. 3).
- Exchangeable sprockets for two working speeds.
- Flanged rotor shaft for easy removal & service.
- Parking stand.
- 3 point linkage, cat. 1.
- Lateral ASA 80 chain drive transmission in oil bath.
- Four blades per flange.















- High carbon solid steel round rotor shaft allows for a deeper working depth.
- Outward turned blades keep the rotor supports clean and maximize working width.
- Heavy duty full size blades.
- Wear protection on chain case.
- Max. working depth 7 1/4".



**JESSE RAST ENTERPRISES (803) 420-4102**



MODEL	T40-142	T40-150	T40-158	T40-166	T40-242	T40-250	T40-258	T40-266
	SHEAR BOLT				SLIP CLUTCH			
 HP	20-40	25-40	30-40	32-40	20-40	25-40	30-40	32-40
 in	42"	50"	58"	66"	42"	50"	58"	66"
 in	47"	55"	63"	72"	47"	55"	63"	72"
 in	32"	40"	48"	56"	32"	40"	48"	56"
 lbs	363	407	451	518	373	417	461	530
 lbs	481	519	540	607	491	529	550	619
 N°	5	6	7	8	5	6	7	8
 N°	20	24	28	32	20	24	28	32
 z	11-14	11-14	11-14	11-14	11-14	11-14	11-14	11-14
 rpm	231/375	231/375	231/375	231/375	231/375	231/375	231/375	231/375
 in	7 1/4"	7 1/4"	7 1/4"	7 1/4"	7 1/4"	7 1/4"	7 1/4"	7 1/4"
 1 3/8"	ASAE cat. 3 shear bolt	ASAE cat. 3 shear bolt	ASAE cat. 3 shear bolt	ASAE cat. 3 shear bolt	ASAE cat. 3 slip clutch	ASAE cat. 3 slip clutch	ASAE cat. 3 slip clutch	ASAE cat. 3 slip clutch

## STANDARD



Manual side-shift



Forward or reverse tilling rotation



Gearbox manufactured by Befco



Lateral ASA 80 chain drive transmission in oil bath



Stamped steel rotor shaft supports and transmission



Rotor shaft with flanges for easy blade replacement



## TILL-RITE T50

25-50 HP (19-37 KW)  
540 rpm - cat. 1



### Rotary tiller with manual side-shift Forward or reverse tilling rotation















- Highly engineered & rugged gearbox.
- Smooth manual side-shift system.
- Adjustable side skids for working depth control.
- Heavy duty shielded PTO shaft with slip clutch safety (1 3/8" ASAE cat. 4).
- Exchangeable sprockets for two working speeds.
- Flanged rotor shaft for easy removal & service.
- Parking stand.
- 3 point linkage, cat. 1.
- Lateral ASA 100 chain drive transmission in oil bath.
- Standard six blades per flange for greater stability and finer soil pulverization.
- Outward turned blades keep the rotor supports clean and maximize working width.
- Heavy duty full size tiller blades.
- Wear protection on chain case.
- Max. working depth 8 3/8".



**JESSE RAST ENTERPRISES (803) 420-4102**



MODEL		T50-350	T50-358	T50-366
	HP	25-50	30-50	35-50
	in	50"	58"	66"
	in	55"	63"	72"
	in	40"	48"	56"
	lbs	481	528	575
	lbs	625	670	708
	N°	6	7	8
	N°	36	42	48
	z	10-13	10-13	10-13
	rpm	226/383	226/383	226/383
	in	8 3/8"	8 3/8"	8 3/8"
	1 3/8"	ASAE cat. 4 slip clutch	ASAE cat. 4 slip clutch	ASAE cat. 4 slip clutch



## STANDARD



Manual side-shift



Forward or reverse tilling rotation



Gearbox manufactured by Befco



Lateral ASA 100 chain drive transmission in oil bath



Stamped steel rotor shaft supports and transmission



Rotor with 6 blades per flange



Rotor shaft with flanges for easy blade replacement

# TILL-RITE T60

35-60 HP (26-45 KW)  
540 rpm - cat. 1















## Rotary tiller with manual side-shift Forward or reverse tilling rotation

- Highly engineered & rugged gearbox.
- Smooth manual side-shift system.
- Adjustable side skids for working depth control.
- Heavy duty shielded PTO shaft with slip clutch safety (1 3/8" ASAE cat. 6).
- Flanged rotor shaft for easy removal & service.
- Parking stand.
- 3 point linkage, cat. 1.
- Lateral ASA 100 chain drive transmission in oil bath.
- Standard six blades per flange for greater stability and finer soil pulverization.
- Outward turned blades keep the rotor supports clean and maximize working width.
- Heavy duty full size tiller blades.
- Wear protection on chain case.
- Max. working depth 8 3/4".

**JESSE RAST ENTERPRISES (803) 420-4102**



MODEL		T60-366	T60-374
	HP	35-60	40-60
	in	66"	74"
	in	72"	81"
	in	56"	63"
	lbs	740	798
	lbs	864	910
	N°	8	9
	N°	48	54
	z	12-14	12-14
	rpm	221	221
	in	8 3/4"	8 3/4"
	1 3/8"	ASAE cat. 6 slip clutch	ASAE cat. 6 slip clutch



## STANDARD



Manual side-shift



Forward or reverse tilling rotation



Gearbox manufactured by Befco



Lateral ASA 100 chain drive transmission in oil bath



Stamped steel rotor shaft supports and transmission



Rotor with 6 blades per flange



Rotor shaft with flanges for easy blade replacement

# TILL-RITE T70

40-70 HP (30-52 KW)  
540 rpm - cat. 1



## Rotary tiller

### Forward or reverse tilling rotation

- Highly engineered & rugged gearbox.
- Adjustable side skids for working depth control.
- Heavy duty shielded PTO shaft with slip clutch safety (1 3/8" ASAE cat. 6).
- Flanged rotor shaft for easy removal & service.
- Parking stand.
- 3 point linkage, cat. 1.
- Lateral ASA 100 chain drive transmission in oil bath.
- Standard six blades per flange for greater stability and finer soil pulverization.
- Outward turned blades keep the rotor supports clean and maximize working width.
- Heavy duty full size tiller blades.
- Wear protection on chain case.
- Max. working depth 8 3/4".



**JESSE RAST ENTERPRISES (803) 420-4102**



## T70-382



HP	in	in	lbs	lbs	N°	N°	z	rpm	in	1 3/8"
40-70	82"	88"	879	1,009	10	60	12-14	221	8 • "	ASAE cat. 6 slip clutch



## STANDARD



Forward or reverse tilling rotation



Gearbox manufactured by Befco



Lateral ASA 100 chain drive transmission in oil bath



Stamped steel rotor shaft supports and transmission



Rotor shaft with flanges for easy blade replacement

# GREEN-RITE GRT

25-70 HP (19-52 KW)  
540 rpm - cat. 1















## Overseeder-aerator & seeder-cultivator

- Special 2- $\frac{13}{16}$ " spacing on rotor for aerating with 3 knives per flange; 4 knives on model 282.
- 2" to 3" suggested working depth with aerator rotor, 7  $\frac{1}{4}$ " working depth with tiller rotor; 8  $\frac{3}{4}$ " on on model 282.
- Seed covering/dethatching adjustable tickler tines.
- High precision metering seed cups made from a nylon/fiberglass composite.
- Parking stand.
- Ground drive system for seed hopper.
- Large capacity seed hopper with agitator.
- Heavy duty shielded PTO shaft with slip clutch safety (1  $\frac{3}{8}$ " ASAE cat. 3 for models 250, 258 & 266, cat. 6 for model 282).
- Corrugated depth control roller made with low weight nylon/fiberglass roller rings.
- Double sided, extra thin profile razor blades reduce impact when aerating over existing turf (available on request).



**JESSE RAST ENTERPRISES (803) 420-4102**



MODEL		GRT-250	GRT-258	GRT-266	GRT-282
	HP	25-45	30-45	32-45	40-70
	in	50"	58"	66"	82"
	in	57"	66"	74"	89"
	lbs	910	998	1,170	1,500
	lbs	1,160	1,245	1,390	1,760
	cu.ft	4.60	5.30	6.00	7.60
	N°	7	8	9	11
	N°	15	18	21	26
	N°	43	52	61	104
	z	11-14	11-14	11-14	12-14
	rpm	231	231	231	221
	in	7 1/4"	7 1/4"	7 1/4"	8 3/4"
	1 3/8"	ASAE cat. 3 slip clutch	ASAE cat. 3 slip clutch	ASAE cat. 3 slip clutch	ASAE cat. 6 slip clutch

## STANDARD



Aerator rotor with straight blades with 2-<sup>13</sup>/<sub>16</sub>" flange spacing



Corrugated roller with nylon/fiberglass rings to compact the ground for optimal seed germination



Precise seed metering cups



Seed calibration handle



Lift hooks easy loading and unloading

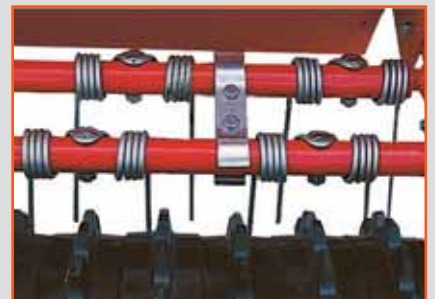

Tickler tines for partial or complete seed incorporation into the ground

**JESSE RAST ENTERPRISES (803) 420-4102**

# SEED-RITE SRT

25-70 HP (19-52 KW)  
cat. 1



## Primary seeder











- 3 point linkage, cat. 1.
- 74" seeding width.
- Heavy duty frame.
- Heavy duty lid with seed splash guard.
- Hopper capacity 7.00 cu. ft.
- Seed box with steel shaft agitator.
- 10 high precision metering seed cups.
- Two lift hooks.
- Wide range of calibration settings per acre.
- Wind guarded seed drop.
- ASA 50 chains with chain tensioners.
- Front 11 1/2" diameter corrugated roller with 28 rings to drive the seed hopper.
- Rear corrugated roller with 29 rings, 9 1/2" in diameter made with low weight nylon/fiberglass.
- Roller spindles: 1 3/8" front and rear, with greasable bearings.
- Two spring-tine track removers.



**JESSE RAST ENTERPRISES (803) 420-4102**



SRT-074

									
HP	in	in	lbs	lbs	cu.ft	N°	N°	N°-Ø	N°-Ø
25-70	74"	80"	1,008	1,190	ASA 50	7	10	28-11 1/2"	29-9 1/2"



STANDARD



Dual front and rear corrugated roller equipped with nylon/fiberglass rings



Lift hooks easy loading and unloading



Precise seed metering cups



Spring-tine tractor tire track removers



Seed distribution engaged by ASA 50 chain transmission





## MOLE 100 / 200 / 300 / 400

15-90 HP (11-67 KW)  
540 rpm - cat. 1 & 2



### Post hole diggers & augers

- Heavy duty boom and yoke for extra strength and long lasting service.
- Choice of 6", 9", 12", 18", 24" & 30" augers.
- Rugged dependable gearbox at 540 rpm provides constant digging power.
- Individually replaceable knives and point.
- Fully welded flighting on all augers.
- Reinforced mounting collar on all augers.
- Safety shielding around auger & PTO.
- 2" output shaft on 200, 300 & 400 series.
- 1 3/8" output shaft with 5/8" adapter bushing on 100 series.

- Heavy duty shielded PTO shaft (1 3/8" ASAE cat. 3) on 200, 300 & 400 series.
- Heavy duty shielded PTO shaft (1 3/8" ASAE cat. 2) on 100 series.
- Fish-tail point standard.

#### STANDARD



Reinforced frame and three point hitch on model 300-512 & 400-512



Driveline with shear pin safety

**JESSE RAST ENTERPRISES (803) 420-4102**





Hook-up stand

MODEL	DIGGERS			
	100-512	200-512	300-512	400-512
HP	15-25	18-40	18-50	18-90
Ø in	2 7/8"	3 1/2"	3 1/2" reinforced	3 1/2" reinforced
Ø in	2 3/8"	2 7/8"	2 7/8" reinforced	2 7/8" reinforced
rpm	180	180	154	135
	3:1	3:1	3.5:1	4:1
lbs	112	200	230	260
lbs	165	235	275	305
	limited Cat.1	Cat.1	Cat.1&2	Cat.1&2
1 3/8"	ASAE cat. 2 shear bolt	ASAE cat. 3 shear bolt	ASAE cat. 3 shear bolt	ASAE cat. 3 shear bolt

MODEL	AUGERS									
	* 106-531	* 109-531	* 112-531	206-531	209-531	212-531	** 218-531	** 224-531	** 230-531	
Ø in	6"	9"	12"	6"	9"	12"	18"	24"	30"	
L in	36"	36"	36"	48"	48"	48"	48"	48"	44"	
lbs	23	40	44	30	52	58	67	100	214	
S in	Single 3/16"	Double 3/16"	Double 3/16"	Single 3/16"	Double 3/16"	Double 3/16"	Double 1/4"	Double 1/4"	Double 15" & 30" 5/16"	

All post hole diggers are crated 2 each. Add \$50 net for single order units.

\* Recommended for model 100-512.

\*\* Available only for models 300-512 & 400-512.



Choice of 6, 9, 12, 18, 24 and 30" auger diameters and 36" or 48" auger lengths



Replaceable knives and points



Heavy duty double flighting on all augers

# BABY-HOP POLY BABY-HOP







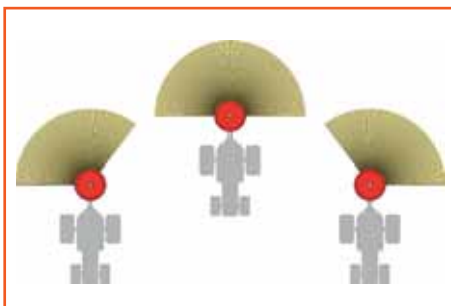

## Fertilizer spreaders Ground driven pull type hitch

- One piece seamless hopper.
- Even left-center-right spread pattern.
- High flotation air tires.
- Easy connecting pull type hitch.
- Sturdy tubular frame.
- Hopper leveling adjustment.
- Sealed heavy duty gearbox with metal gears.
- Ground controlled distribution.
- Polyethylene hopper with stainless steel bottom standard on models 103-230 & 106-230.



Adjustable spread pattern



MODEL	BABY-HOP	
	103-130	106-130
 lbs	62	84
 lbs	100	125
 cu.ft/lbs	3.71 / 237	5.30 / 339
 ft	3'-20"	3'-20"
 in	32"	35"
 in	39.6"	44.4"
 N°-in	2-13"x 6"	2-16"x 8"

POLY BABY-HOP	
103-230	106-230
62	84
100	125
3.71 / 237	5.30 / 339
3'-20"	3'-20"
32"	35"
39.6"	44.4"
2-13"x 6"	2-16"x 8"

NOTE: POUNDAGE capacity calculated @ 13-13-13 fertilizer weight of 64 lbs. per cu. ft.



### STANDARD



Gate opening control



Sealed gearbox manufactured by Befco with metal gears

### STANDARD



Bottom plate in stainless steel

# HOP / POLY-HOP

16-50 HP (12-37 KW)  
540 rpm - cat. 1



## Fertilizer spreaders

- One piece seamless hopper.
- Selective double gate opening on 206, 209 & 212.
- Adjustable ejector spoon to center spread on 203 model.
- Sealed heavy duty gearbox.
- Fixed agitator.
- Adjustable spreading fins on 209 & 212 models.
- Heavy duty shielded PTO shaft (1 3/8" ASAE cat. 1).
- Sturdy tubular frame.
- 3 point linkage, limited cat. 1 on 203 & 206 models, cat. 1 on 209 & 212 models.
- Quick hitch compatible standard on models 209, 212 and optional on models 203.
- Safety shields standard.

MODEL	HOP			
	203-120	206-121	209-121	212-121
HP	16-30	16-30	20-50	20-50
lbs	81	102	125	136
lbs	116	145	160	171
cu.ft/lbs	3.71 / 237	5.30 / 339	8.58 / 549	11.95 / 765
ft	23'	23'	46'	46'
in	32"	35"	42"	48"
in	31"	34"	40"	46"
1 3/8" ASAE cat. 1	ASAE cat. 1	ASAE cat. 1	ASAE cat. 1	ASAE cat. 1

NOTE: Poundage capacity calculated @ 13-13-13 fertilizer weight of 64 lbs. per cu. ft.  
All Hop fertilizers are priced at 2 per pallet. Add \$25 net for single unit orders.

**JESSE RAST ENTERPRISES (803) 420-4102**



## Fertilizer spreaders with polyethylene hoppers

- Polyethylene hopper with stainless steel bottom standard.
- Sturdy tubular frame.
- Selective double opening gate on 206, 209 & 212 models.
- Heavy duty shielded PTO shaft (1 3/8" ASAE cat. 1).
- Sealed heavy duty gearbox.
- Fixed agitator.
- 3 point linkage, limited cat. 1 on 203 & 206 models, cat. 1 on 209 & 212 models.
- Quick hitch compatible standard on models 209, 212 and optional on models 203.
- Safety shields standard.

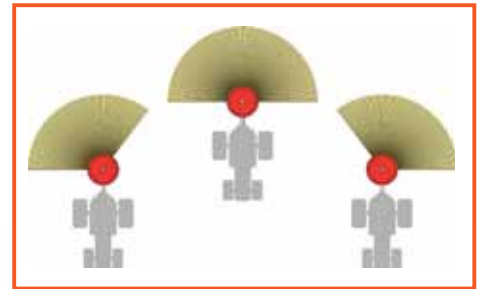

Adjustable spread pattern



POLY-HOP			
203-220	206-221	209-421	212-421
16-30	16-30	20-50	20-50
81	102	125	136
116	145	160	171
3.71 / 237	5.30 / 339	8.58 / 549	11.95 / 765
23'	23'	46'	46'
32"	35"	42"	48"
31"	34"	40"	46"
ASAE cat. 1	ASAE cat. 1	ASAE cat. 1	ASAE cat. 1

## STANDARD

Stainless steel adjustable spreader wings on 209 & 212 models



Stainless steel hopper bottom plate



Stainless steel gates opening control on 206, 209 & 212 models



NOTE: Poundage capacity calculated @ 13-13-13 fertilizers weight of 64 lbs per cu. ft. All Hop fertilizers are priced at 2 per pallet. Add \$25 net for single units orders.

## TURBO-HOP 301 / 303

20-60 HP (15-45 KW)  
540 rpm - cat. 1 & 2







### Pendular spreaders

- Sturdy tubular frame.
- Heavy duty cast iron gearbox in oil bath.
- Accurate flow control adjustment.
- Ideal for the distribution of fertilizer, seed, salt and sand where accuracy and precision in application are needed.
- Full spread or left / right discharge pattern.
- Polyethylene hopper.
- Spreader spouts made of nylon and reinforced fiberglass.
- Stainless steel opening control disc.
- Cast iron anti-wear agitator.
- 3 point linkage, cat. 1 on model 301 and cat. 1&2 on model 303.
- Heavy duty shielded PTO shaft (1 3/8" ASAE cat. 1) with shock absorber and shear bolt safety.
- Safety shields standard.



**JESSE RAST ENTERPRISES (803) 420-4102**



MODEL		301-300	301-400	303-600	303-800	303-999
	HP	20-60	20-60	20-60	20-60	20-60
	lbs	256	267	419	448	455
	mph	2 to 10	2 to 10	2 to 10	2 to 10	2 to 10
	cu.ft/lbs	9.00 / 576	12.80 / 820	20.6 / 1,318	30.3 / 1,939	36.1 / 2,310
	ft	17'-47'	17'-47'	17'-47'	17'-47'	17'-47'
	in	44"	48"	38"	43"	47"
	1 3/8"	ASAE cat. 1 shear bolt	ASAE cat. 1 shear bolt	ASAE cat. 1 shear bolt	ASAE cat. 1 shear bolt	ASAE cat. 1 shear bolt

NOTE: Poundage capacity calculated @ 13-13-13 fertilizers weight of 64 lbs per cu. ft.

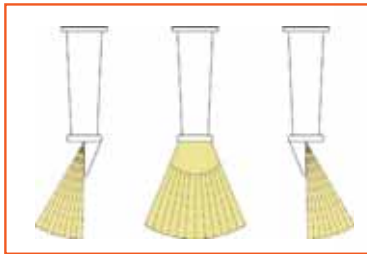

Adjustable spread pattern

### STANDARD



Corrosion resistant polyethylene hopper



Heavy duty gearbox in oil bath manufactured by Befco



Distributing unit in stainless steel and agitator in stamped steel



Graded scale for accurate flow control adjustment

**JESSE RAST ENTERPRISES (803) 420-4102**

# CORE AERATOR SD

20-50 HP (15-37 KW)  
cat. 1



## Standard duty core aerators

- Hub spacing 6 1/2".
- Special high tensile steel shafts on the rotors.
- 2 bronze bushings per rotor.
- 8 gauge formed steel support panels.
- All panels support rotors from all sides.
- 1 1/4" rotor support shaft.
- 3/8" formed Cat. 1 "A" frame.
- Machine equipped with spikes instead of spoons is available on request.
- 3 point linkage, Cat. 1.
- 6 spoons per hub.
- All flanges are welded to rotors.
- Flange thickness 3/16".
- 3 support stands.
- 3/4" hardened steel spoons.
- Front or rear tractor mounting.

MODEL	BCA-048	BCA-060	BCA-072
HP	20-50	20-50	20-50
in	48"	60"	72"
in	54"	65"	78"
lbs	284	357	401
N°	4	5	6
N°	8	10	12
N°	48	60	72
in	4 1/2"	4 1/2"	4 1/2"
in	12" x 15"	19" x 15"	25" x 15"
lbs	78 ea.	125 ea.	160 ea.

### STANDARD



Front or rear tractor mounting



Both hub flanges are welded and equipped with two bronze bushings per rotor





# CORE AERATOR HD

20-70 HP (15-52 KW)  
cat. 1 & 2



heavy duty



## Heavy duty core aerators

- Hub spacing 6 1/2".
- Special high tensile steel shafts on the rotors.
- 2 bronze bushings per rotor.
- 3/16" formed steel support panels.
- All panels support rotors from all sides.

- 1 1/4" rotor support shaft.
- 3/8" formed Cat. 1 & 2 "A" frame.
- Machine equipped with spikes instead of spoons is available on request.
- 3 point linkage, Cat. 1 & 2.
- 8 spoons per hub.
- All flanges are welded to rotors.
- Flange thickness 3/16".
- 3/4" hardened steel spoons.
- Front or rear tractor mounting.
- 3 support stands.

MODEL		BCA-260	BCA-272
	HP	20-70	20-70
	in	60"	72"
	in	65"	78"
	lbs	444	549
	N°	5	6
	N°	10	12
	N°	80	96
	in	4 1/2"	4 1/2"
	in	19" x 21"	25" x 21"
	lbs	170 ea.	220 ea.

### STANDARD



Eight spoons per flange



Choice of hollow spoons or solid spikes

# SOIL PULVERIZERS SD

25-50 HP (19-37 KW)  
cat. 1



## Standard duty soil pulverizers

- 3/8" steel spikes fully welded in a timed scroll pattern on a heavy walled roller with two 160 lbs compression springs.
- Optional 2<sup>nd</sup> spiked roller available with two 80 lbs compression springs.
- 10" (49.1 lb/ft) frame beam.
- Reversible heat treated 1/2" x 2" shanks.
- 3 point linkage, cat. 1.
- 5 9/16" diameter spiked roller tube.
- Self aligning 1" bearings on roller.
- Formed plate "A" frame.

MODEL	BPL-048	BPL-060	BPL-072
HP	25-50	25-50	25-50
in	48"	60"	72"
lbs	496	652	679
lbs	544	702	729
N°	17	21	25
N°	70	88	106
in	2 13/16"	2 13/16"	2 13/16"
in	4 1/2"	4 1/2"	4 1/2"
lbs	160 lbs per spring	160 lbs per spring	160 lbs per spring

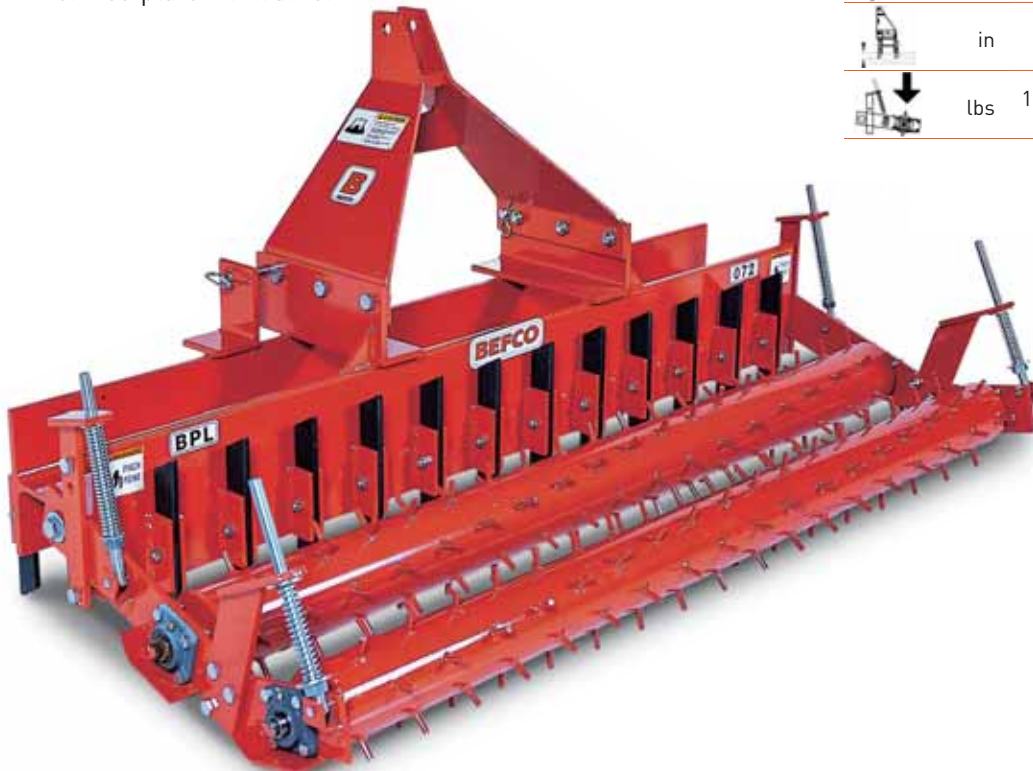



# SOIL PULVERIZERS HD

40-90 HP (30-67 KW)  
cat. 1



## Heavy duty soil pulverizers

- $\frac{3}{8}$ " steel spikes fully welded in a timed scroll pattern on a heavy walled roller with two 160 lbs compression springs.
- Optional 2<sup>nd</sup> spiked roller available with two 80 lbs compression springs.
- 12" (59.4 lb/ft) frame beam.
- Reversible heat treated  $\frac{1}{2}$ " x 2" shanks.
- 3 point linkage, cat. 1.
- 6  $\frac{5}{8}$ " diameter spiked roller tube.
- Self aligning 1" bearings on roller.
- Formed plate "A" frame.

MODEL	BPL-272	BPL-284
HP	40-90	40-90
in	72"	84"
lbs	781	875
lbs	846	940
N°	25	29
N°	106	124
in	2 $\frac{13}{16}$ "	2 $\frac{13}{16}$ "
in	4 $\frac{1}{2}$ "	4 $\frac{1}{2}$ "
lbs	160 lbs per spring	160 lbs per spring

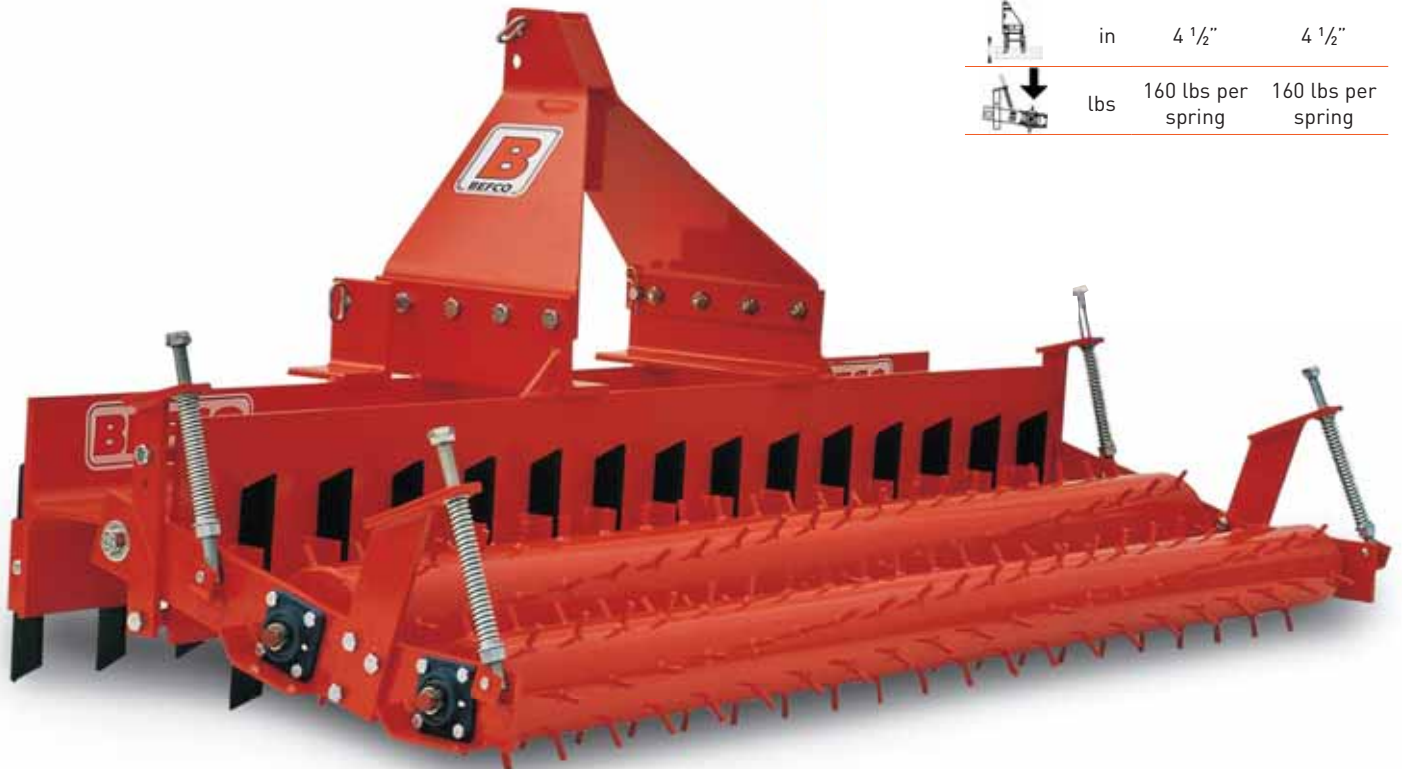





**JESSE RAST ENTERPRISES (803) 420-4102**

# BOX SCRAPER

16-65 HP (12-48 KW)  
cat. 1



- Roll formed moldboard.
- 3 point linkage, cat. 1.
- 2 bolt-on 1/2" x 6" heat treated blades with reversible cutting edge.
- Hardened steel ripping shanks with replaceable tips.
- Reinforced box design.

MODEL		BBS-C48	BBS-060	BBS-072	BBS-084
		SUBCOMPACT SERIES		STANDARD DUTY SERIES	
	HP	16-30	25-65	25-65	25-65
	in	48"	60"	72"	84"
	lbs	251	470	530	630
	lbs	276	505	570	680
	N°	4	5	6	7

Standard duty series



Subcompact series



# GRADING SCRAPER

16-65 HP (12-48 KW)  
cat. 1



Standard duty series

Subcompact series

MODEL		BGS-C48	BGS-060	BGS-072	BGS-084
		SUBCOMPACT SERIES	STANDARD DUTY SERIES		
	HP	16-30	25-65	25-65	25-65
	in	48"	60"	72"	84"
	in	52"	64"	76"	89"
	lbs	350	592	703	764
	lbs	386	628	739	800
	N°	-	5	6	7
	in	10 3/4"	12 1/2"	12 1/2"	12 1/2"
	in	0"-1 1/2"	0"-1 1/2"	0"-1 1/2"	0"-1 1/2"

- 3 point linkage, cat. 1.
- Adjustable height grading blades.
- Adjustable hardened steel ripping shanks with replaceable tips, on standard duty series.
- Heavy duty frame.
- 2 reversible and replaceable bolt-on 1/2" x 6" heat treated high carbon steel blades.
- Replaceable full length skid shoes.

## STANDARD



Adjustable height grading blades



Skid shoes

**JESSE RAST ENTERPRISES (803) 420-4102**

# REAR BLADE SD

16-50 HP (12-37 KW)  
cat. 1



## Standard duty rear blades

- 5 forward & 5 reverse positions on standard duty series.
- 3 forward and 3 reverse positions on subcompact series.
- Sturdy frame construction.
- Left or right offset.
- 3 tilt positions on standard duty series.
- 1/2" x 6" heat treated reversible cutting blade.
- 1/4" moldboard thickness.
- 3 point linkage, cat. 1.

MODEL		BRB-C48	BRB-C60	BRB-072	BRB-084
		SUBCOMPACT SERIES		STANDARD DUTY SERIES	
	HP	16-30	16-30	25-50	25-50
	in	48"	60"	72"	84"
	lbs	139	158	275	294
	lbs	189	208	325	344
		-	-	14°	14°
		16°	16°	16° & 32°	16° & 32°
	in	6"	6" or 12"	6" or 12"	6" or 12"

Standard duty series.

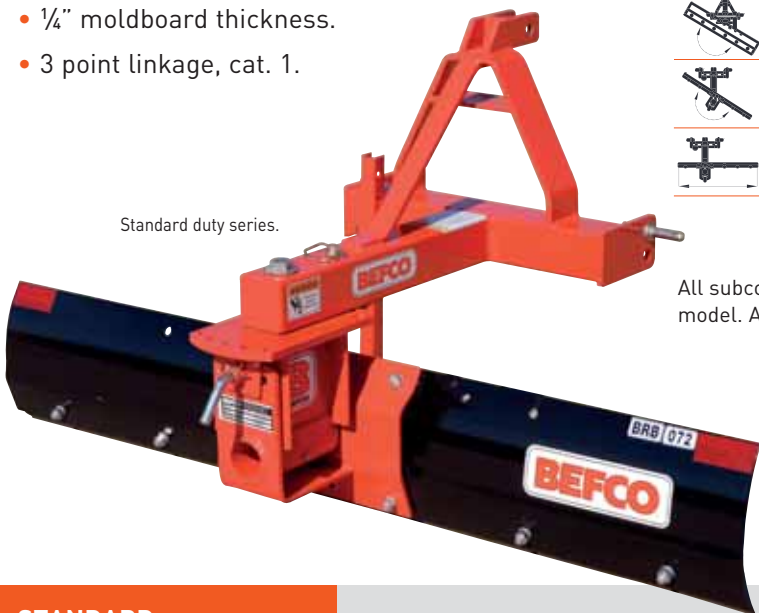

All subcompact and standard duty blades are crated 2 each of the same model. Add \$50 net for single order units.

Subcompact series.



## STANDARD



Front or rear tractor mounting

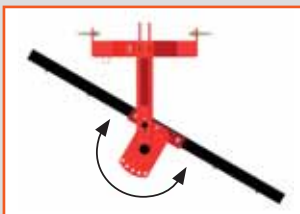

Up to 32° angling on standard duty blades

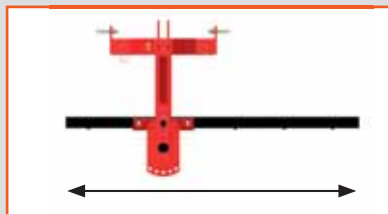

Up to 12" offset



Up to 14° tilt on standard duty blades

**JESSE RAST ENTERPRISES (803) 420-4102**



# REAR BLADE HD

30-80 HP (22-60 KW)  
cat. 1 & 2



## Heavy duty rear blades

- 16 forward & 16 reverse positions.
- Right or left offset.
- 5 tilt positions.
- 3 point linkage, cat. 1 & 2.
- ½" x 6" heat treated reversible cutting blade.
- ¼" moldboard thickness.
- Reinforced moldboard for increased strength.



MODEL	BRB-284	BRB-296
HP	30-80	30-80
in	84"	96"
lbs	524	561
lbs	602	644
	15° & 30°	15° & 30°
	up to 60°	up to 60°
in	up to 21"	up to 21"

### STANDARD



Front or rear tractor mounting



Up to 60° angling



Up to 21" offset



Up to 30° tilt

**JESSE RAST ENTERPRISES (803) 420-4102**

# LANDSCAPE RAKE

16-65 HP (12-48 KW)  
cat. 1



- 5 forward & 5 reverse positions on standard duty series.
- 3 forward and 3 reverse on subcompact series.
- Sturdy frame construction.
- 2" center tine spacing.
- 2 hole tine 5/16" x 1" on standard duty series.
- 1 hole tine 5/16" x 1" on subcompact series.
- 3 point linkage, cat. 1.



## STANDARD



Front or rear tractor mounting



Up to 32° angling on standard duty rakes

	MODEL	BLR-C48	BLR-C60	BLR-072	BLR-084	BLR-096
		SUBCOMPACT SERIES		STANDARD DUTY SERIES		
	HP	16-30	16-30	25-65	25-65	25-65
	in	48"	60"	72"	84"	96"
	lbs	135	156	248	274	314
	lbs	180	198	293	319	359
		16°	16°	16° & 32°	16° & 32°	16° & 32°
	N°	24	30	36	42	48

All subcompact and standard duty rakes are crated 2 each of the same model. Add \$50 net for single order units.

**JESSE RAST ENTERPRISES (803) 420-4102**



# SICKLE BAR MOWERS

20-75 HP (15-56 KW)  
540 rpm - cat. 1 & 2



- 3 point linkage, cat. 1 & 2.
- Double action sickle bar.
- Single action hydraulic cylinder with restrictor.
- Safety release standard on all units.
- Transport lock bar secures cutting bar for transport and storage.
- Transport blade guard standard.
- Equipped with cylinder stop to raise cutting bar using tractor's hydraulic system.
- Ideal for set-aside, conservation acreage and ditchbank mowing.
- Delivered with extra cutting blade.
- Will mow 90° up and 55° down.
- Heavy duty shielded pto shaft (1 3/8" ASAE cat. 4).



BSB-284

## STANDARD



Spring loaded blade guides for quick and easy blade replacement



Easy to inspect and adjust belt tensioner



Cast aluminium connecting rods with cooling fins

MODEL		BSB-272	BSB-284	BSB-296
	HP	20-75	20-75	20-75
	in	72"	84"	96"
	in	130"	142"	154"
	lbs	628	650	672
	lbs	717	750	782
	mph	9	9	9
		Hydraulic	Hydraulic	Hydraulic
	1 3/8"	ASAE cat. 4	ASAE cat. 4	ASAE cat. 4





# FINGER WHEEL RAKES

16-80 HP (12-60 KW)  
cat. 1

RS2-04V

- 3 point linkage, cat. 1.
- Cast steel hubs with greasable tapered bearings.
- Quick hitch compatible on models RS2-02R, RS2-03R, RS2-04V & RS2-06V
- Finger wheel rakes may also be used for spreading (2, 3, 4 & 6 wheel models only) or turning hay (RS2-04R & RS2-06R models only).
- Lifts hay gently, even from undulating terrain.
- Bent elbows allow better hay flow under heavy working conditions.

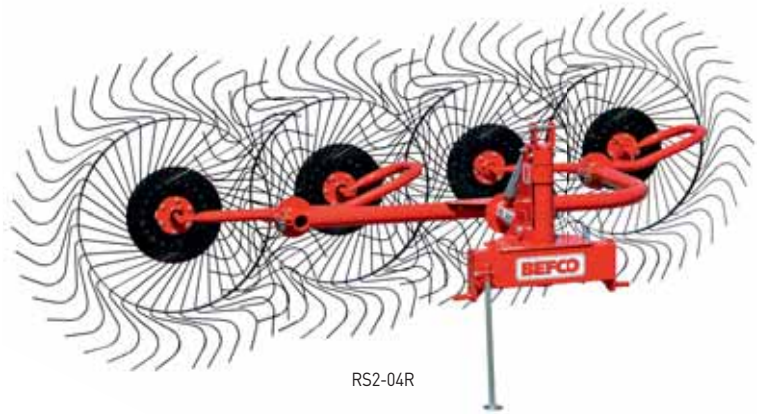

RS2-04R

## STANDARD

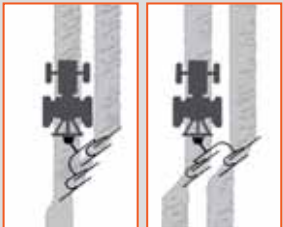

Rakes can be used for raking, turning and spreading



Cast steel hubs with greasable tapered bearings

MODEL		RS2-02R	RS2-03R	RS2-04R	RS2-05R	RS2-06R	RS2-04V	RS2-06V
	HP	16-30	16-30	30-80	30-80	30-80	16-30	16-30
	N°	2	3	4	5	6	4	6
	Ø in	56"	56"	56"	56"	56"	56"	56"
	N°	40	40	40	40	40	40	40
	Ø in	3/32"	3/32"	3/32"	3/32"	3/32"	3/32"	3/32"
	ft	4'3"	6'5"	8'6"	11'	12'9"	11'6"	15'10"
	ft	7'4"	8'4"	4'9"	7'5"	7'5"	10'2"	12'7"
	ft	7'6"	10'	12'10"	14'6"	17'3"	7'6"	10'
	mph	14	14	14	14	14	14	14
	lbs	194	291	388	495	602	353	547

NOTE: For left hand models order with "L" suffix. (ie. RS2-04L)





HRC-08V

## FINGER WHEEL "V" RAKES

16-80 HP (12-60 KW)

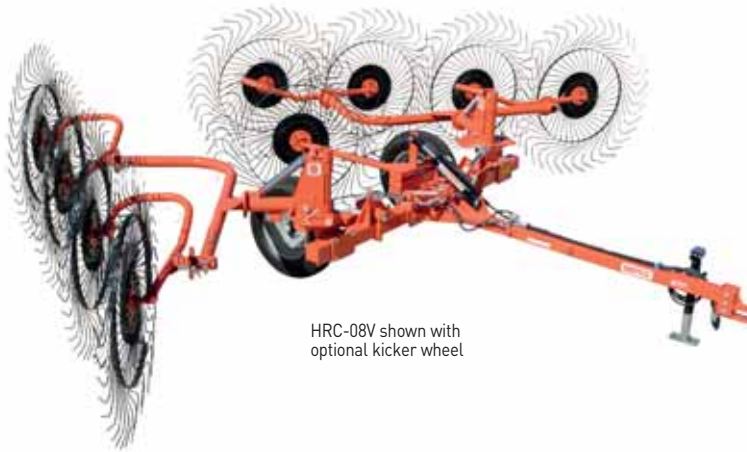

HRC-08V shown with optional kicker wheel

HRC-08V	HRC-10V	HRC-12V
30-80	30-80	30-80
8	10	12
56"	56"	56"
40	40	40
3/32"	3/32"	3/32"
21'4"	23'4"	25'7"
8'	8'	8'
8'10"	10'	12'1"
14	14	14
1,290	1,457	1,623

- Working speed of up to 14 mph, low costs of maintenance, and ease of use make these units indispensable for raking hay.
- Floating rake wheels with spring steel tines follow ground contour evenly.
- Multiple adjustment capabilities allow operator to adjust raking width, windrow width and raking angle.
- Pull type 8, 10 and 12 wheel rakes with double action hydraulic cylinders for easy transportation and storage.
- Hydraulic ball valves allow for single side operation and lock rakes during transport and storage.
- Narrow 8' transport width allows rakes to be easily transported to different work locations.
- 8 and 12 wheel rakes may be adjusted to spread or turn crop.
- Optional center kicker wheel with additional hydraulic cylinder.

### STANDARD

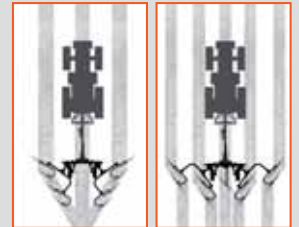

"V" rakes can be used for raking, turning and spreading



Two hydraulic cylinders with ball valves



Narrow 8" transport width









Springs adjust the pressure of the wheels to the ground

# TEDDERS

20-50 HP (15-37 KW)  
540 rpm



- Heavy frame construction.
- High strength steel tine arms.
- Large diameter 15" x 6" pneumatic tires.
- Easy pull type hook up.
- Heavy duty shielded PTO shaft with ratchet torque limiter.
- Spring steel double hay tines.
- Sturdy guard rail for added safety.

MODEL	DRP-300	
	HP	20-50
	ft	10'
	lbs	408
	N°	2
	N°	6
	1 3/8"	ASAE cat. 2 ratchet torque limiter

All DRP-300 are crated 2 each.  
Add \$50 net for single order units.

**JESSE RAST ENTERPRISES (803) 420-4102**





**JESSE RAST ENTERPRISES (803) 420-4102**

# OPTIONALS

## OPTIONALS CYCLONE C30-CE5

005-600

• Mulching kit



001-600

• Front antiscalping roller



## OPTIONALS CYCLONE C30

• Mulching kit



004-600

C30-RD4

005-600

C30-RD5

006-600

C30-RD6

001-600

• Front antiscalping roller



001-700

• Quick hitch adapter



FRTXC30

• Front mount C30  
(factory installed)





## OPTIONALS CYCLONE C50

- Mulching kit



**005-700** C50-RD5

**006-700** C50-RD6

**007-700** C50-RD7

**009-9915**



- Front antiscalping roller  
(standard on C50-RD7 model)

**002-800**

- Quick hitch adapter



**FRTXXC50**



- Front mount C50  
(factory installed)

## OPTIONALS CYCLONE C70

**002-800**

- Quick hitch adapter



**FRTXXC70**



- Front mount C70  
(factory installed)

## OPTIONALS CYCLONE FLEX

**009-9817**

- Hydraulic unlocking system



- Mulching kit



**009-9556** 412-SFL

**009-9557** 415-SFL

**009-9558** 417-SFL

**009-9597**

- Floating hitch, additional



**009-9599**

- Roadway kit



## OPTIONALS CYCLONE SUPER FLEX

009-9817

• Hydraulic unlocking system



• Mulching kit



009-9556 412-SFL

009-9557 415-SFL

009-9558 417-SFL

009-9559 420-SFL

009-9597

• Front floating hitch, additional



009-9599

• Roadway kit



## OPTIONALS HURRICANE H40-S

009-9206

• Side skirts



009-9560

• Overrunning clutch for driveline



• Rotor with dethatching blades (factory installed)

DBD48H40 H40-S48

DBD60H40 H40-S60

DBD72H40 H40-S72



• Rotor with reverse "Y" blades (factory installed)

YBD48H40 H40-S48

YBD60H40 H40-S60

YBD72H40 H40-S72



• Rotor with triangular paddle blades (factory installed)

TBD48H40 H40-S48

TBD60H40 H40-S60

TBD72H40 H40-S72



• Rotor with hammers (factory installed)

HBD48H40 H40-S48

HBD60H40 H40-S60

HBD72H40 H40-S72

009-9207

• Hydraulic cylinder for side shift

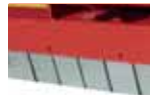

• Front steel deflectors

009-9208 H40-S48

009-9209 H40-S60

009-9210 H40-S72

RVRXXH40

• Reverse rotation (factory installed)



FRTXXH40

• Front mount H40 (factory installed)

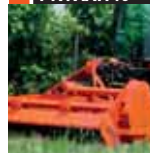



## OPTIONALS HURRICANE H70

**009-9691**

- Gauge wheels with laminated tires H70



- Rotor with dethatching blades (factory installed)

**DBD60H70** H70-060

**DBD72H70** H70-072

**DBD88H70** H70-088



- Rotor with reverse "Y" blades (factory installed)

**YBD60H70** H70-060

**YBD72H70** H70-072

**YBD88H70** H70-088



- Rotor with triangular paddle blades (factory installed)

**TBD60H70** H70-060

**TBD72H70** H70-072

**TBD88H70** H70-088



- Rotor with hammers (factory installed)

**HBD60H70** H70-060

**HBD72H70** H70-072

**HBD88H70** H70-088

**RVRXXH70**

- Reverse rotation (factory installed)



**FRTXXH70**

- Front mount H70 (factory installed)



**DST88H70**

- Dust skirt 88" (factory installed)



## OPTIONALS DESTROYER D90

**GDTXXD90**

- Gearbox with dual PTO (factory installed)



**009-9969**

- Side skirts



**FRTXXD90**

- Front mount D90 (factory installed)



## OPTIONALS TORNADO BRC

009-9986

• Side skids



## OPTIONALS TILL-RITE T30

RVRXXT30

• Reverse rotation (factory installed)



## OPTIONALS TILL-RITE T40



• Aerator rotor

009-9852 T40-150, T40-250

009-9853 T40-158, T40-258

009-9854 T40-166, T40-266

RVRXXT40

• Reverse rotation (factory installed)



## OPTIONALS TILL-RITE T50

RVRXXT50

• Reverse rotation (factory installed)





## OPTIONALS TILL-RITE T60

**RVRXXT60**

• Reverse rotation (factory installed)



## OPTIONALS TILL-RITE T70

**RVRXXT70**

• Reverse rotation (factory installed)



**009-9855**

• Areator rotor T70-382



## OPTIONALS GREEN-RITE GRT

**009-9875**

• Gauge wheels for all models



• Front roller

**009-9648** GRT-250

**009-9516** GRT-258

**009-9563** GRT-266

**009-9566** GRT-282

Note: units may utilize gauge wheels or front roller for depth control, but not both

• Tiller rotor



**009-9649** GRT-250

**009-9517** GRT-258

**009-9564** GRT-266

**009-9567** GRT-282



• Rear roller scraper

**009-9189** GRT-250

**009-9190** GRT-258

**009-9191** GRT-266

**009-9192** GRT-282

• Cast iron roller rings  
(factory installed)



**CSR50GRT** GRT-250

**CSR58GRT** GRT-258

**CSR66GRT** GRT-266

**CSR82GRT** GRT-282



• Seed conveyor kit

**009-9139** GRT-250

**009-9140** GRT-258

**009-9141** GRT-266

**009-9142** GRT-282

## OPTIONALS SEED-RITE SRT

**CSR74SRT**

• Cast iron roller rings (factory installed)



**009-9985**

• Seed rate speed reduction kit



**009-9138**

• Seed conveyor kit



**009-9930**

• Rear expanded roller frame for seed covering/  
dethatching with adjustable tickler tines



## OPTIONALS MOLE 200 / 300

**009-9851**

• Hook-up stand all models



**009-9154**

• Hydraulic down force kit 200-512



**009-9155**

• Hydraulic down force kit 300-512 & 400-512 model



**PHD-003**

• Auger positioning handle all models



## OPTIONALS BABY-HOP POLY BABY-HOP

**AA1-120**

• Deflector shield



**009-9856**

• Remote gate control



• Hopper cover

**009-9720** for all 103 models

**009-9721** for all 106 models





## OPTIONALS

### HOP

### POLY-HOP

**009-9979** • Tumbling style agitator for all 203 models



**009-9978** • Tumbling style agitator for all 206, 209 & 212 models



**009-9458** • Side row discharge for all 209 & 212 models



**009-9524** • Deflector shield for all 203 & 206 models



**009-9638** • Deflector shield for all 209 & 212 models



**009-9856** • Remote gate control for all 203 models



**009-9850** • Remote gate control for all 206, 209 & 212 models



**009-9913** • Filter grate for all 209 & 212 models



• Hopper cover **009-9720** for all 203 models

**009-9721** for all 206 models

**009-9722** for all 209 models

**009-9723** for all 212 models



**009-9239** • Quick hitch adapter for all 203 models



## OPTIONALS

### TURBO-HOP 301

**009-9452** • Short spout for sand and salt



**009-9451** • Rubber insert for damp material



**009-9453** • Agitator extension



**009-5370** • Left only & right only directional attachment



001-4984

• Locking nut for spout



009-9913

• Filter grate



009-9456

• Hydraulic control



• Hopper cover

009-9722

301-300

009-9723

301-400



## OPTIONALS TURBO-HOP 303

009-9452

• Short spout for sand and salt



009-9451

• Rubber insert for damp material



009-9454

• Agitator extension



009-5370

• Left only & right only directional attachment



001-4984

• Locking nut for spout



009-9457

• Hydraulic control



009-5410

• Filter grate



• Hopper cover

009-9725

303-600

009-9726

303-800

009-9727

303-999





## OPTIONALS CORE AERATOR SD



- Steel weight sand tank, price per unit

**009-9731** BCA-048

**009-9732** BCA-060

**009-9733** BCA-072



- Unit with spikes instead of spoons (factory installed)

**SP048BCA** BCA-048

**SP060BCA** BCA-060

**SP072BCA** BCA-072

**FRTSDBCA**

- Front mounted (factory installed)



## OPTIONALS CORE AERATOR HD



- Steel weight sand tank, price per unit

**009-9734** BCA-260

**009-9735** BCA-272



- Unit with spikes instead of spoons, (factory installed)

**SP260BCA** BCA-260

**SP272BCA** BCA-272

**FRTHDBCA**

- Front mounted (factory installed)



## OPTIONALS SOIL PULVERIZERS SD



- 2nd rear roller assembly Ø 5"

**009-9887** BPL-048

**009-9636** BPL-060

**009-9637** BPL-072

## OPTIONALS SOIL PULVERIZERS HD



- 2nd rear roller assembly Ø 5 9/16"

**009-9646** BPL-272

**009-9647** BPL-284

## OPTIONALS REAR BLADE SD

**BRB-001**

- Skid shoes



## OPTIONALS REAR BLADE HD

**BRB-001**

- Skid shoes



**BRB-002**

- Hydraulic offset control



## OPTIONALS LANDSCAPE RAKE BLR

**009-9159**

- Gauge wheels (standard duty series)



**BLR-002**

- Gauge wheels (subcompact series)





## OPTIONALS

# FINGER WHEEL "V" RAKES

009-9982

- Kicker wheel for HRC models (includes hydraulic cylinder)



## OPTIONALS

# TEDDERS

009-9966

- Hydraulic lift kit for model DRP-480

